

D122600

Float AGM Battery Block

Discover® AGM Series VRLA Industrial Batteries provide superior high integrity and reliability for commercial, industrial, and private applications. The maintenance-free Valve Regulated Lead Acid (VRLA) construction make Discover® Standard AGM Series Batteries the definitive choice for broadband and CableTV (CATV), Uninterruptible Power Supplies (UPS), telecommunications, and electronics and security applications.

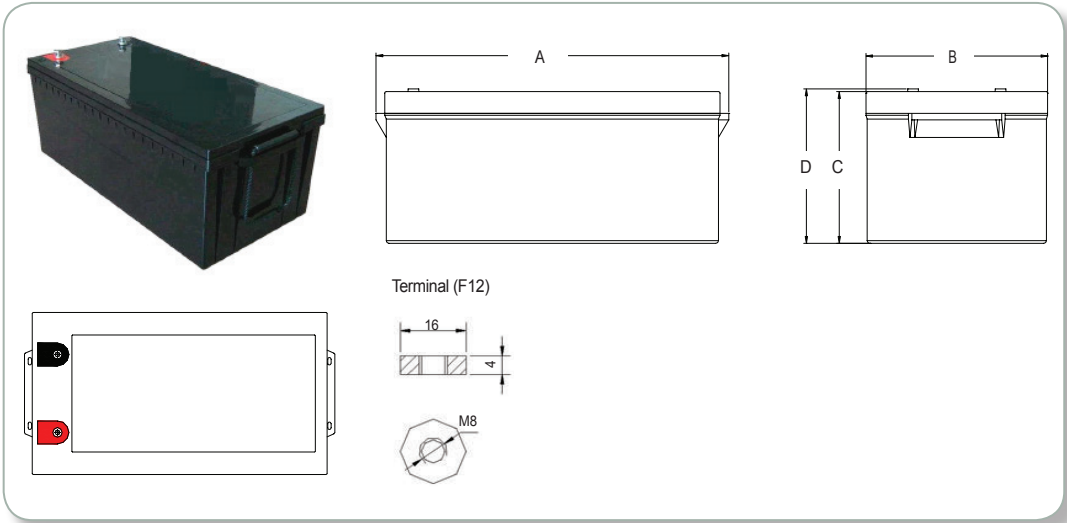

Mechanical Specifications

Industry Reference	-	
Length [A]	20.5 in	520 mm
Width [B]	10.6 in	268 mm
Height [C]	8.66 in	220 mm
Total Height [D]	8.82 in	224 mm
Weight	159.8 lbs	72.5 kgs
Terminal (Opt'l)	F12	
Terminal Torque (NM)	9.5 - 10.5	
Cells	6 Cell	

Electrical Specifications

Volts	12 V
RINT	4 mOhms
Short Circuit (68°F / 20°C)	-
20 HR	270 Ah
10 HR	260 Ah
5 HR	225 Ah
1 HR	168 Ah
15 MIN	-
Standard Charge	50°F / -10°C to 122°F / 50°C
Standard Discharge	-4°F / -20°C to 122°F / 50°C
Maximum Discharge**	-40°F / -40°C to 140°F / 60°C

CAUTION:** Extra considerations must be given to depths of discharge, operating voltages and currents when designing systems for use at maximum temperatures.

Discharge Constant Current (Amperes at 77°F / 25°C)

End Point V/C	5 MIN	10 MIN	15 MIN	30 MIN	1 HR	3 HR	5 HR	10 HR	20 HR
1.60V	-	600	417	275	168	71.9	46.3	26.3	13.6
1.65V	-	574	397	269	165	71.0	46.0	26.2	13.6
1.70V	-	548	377	261	162	70.0	45.5	26.1	13.5
1.75V	-	522	356	252	159	69.9	45.0	26.0	13.5
1.80V	-	491	330	243	153	68.7	44.3	25.8	13.4

Discharge Constant Power (Watts at 77°F / 25°C)

End Point V/C	5 MIN	10 MIN	15 MIN	30 MIN	45 MIN	1 HR	2 HR	3 HR	5 HR
1.60V	-	1020	767	531	410	335	194	148	98.4
1.65V	-	1004	762	528	408	332	193	147	98.1
1.70V	-	985	755	524	405	329	191	146	97.8
1.75V	-	949	746	521	402	326	190	145	97.4
1.80V	-	910	735	515	399	322	188	143	97.0

AGM Series Features & Benefits

- Tank formed lead-tin-calcium plates deliver consistent dependable performance and promote long life.
- Maintenance-free technology
- 99% gas recombination for extended life in float applications.
- Multiple terminal, configuration options and carrying handles available with most models.
- Classified as a non-spillable battery and is not restricted for transportation by:
 - Air (IATA/ICAO provision 67)
 - Surface (DOT-CFR-HMR49)
 - Water (per IMDG amendment 27).
- Flame retardant ABS case and cover with UL94 V0 rating available.
- UL924 recognized flame arresting low pressure safety vents available.
- 98% recyclable.
- Up to 12 year design life in float service.

Certifications and Standards

Designed in accordance with and published in compliance with applicable BCI, IEC and BS EN standards, including:

- IEC60896-21/22
- BS EN 60254-1:2005
- AS/NZS 4029.2:2000 BS EN 60254-1:2005 (MOD).

Discover® and its facilities and products are certified to multiple standards:

- ISO, UL, QS, and TUV standards
- ETTS Germany
- Euro Bat classification for Environmental Stewardship Standards.



Contact Us

Discover Energy Corp.
 Suite 880-999 West Broadway
 Vancouver BC V5Z 1K5 Canada
 Tel: 604.730.2877
 Email: info@discover-energy.com
www.discover-energy.com

Charging

Max Charge / Discharge Currents	Peak (5 seconds)	Peak (10 seconds)	Max Continuous
Charge	1C20Hr	0.75C20Hr	0.25C20Hr
Discharge	15C20Hr	10C20Hr	0.5C20Hr

“Float” or “Stand-By” Service: Hold a constant voltage source of 2.25vpc to 2.30vpc continuously. When held at this voltage, the battery will seek its own current level and maintain itself in a fully charged condition.

Cyclic Application: Limit initial currents to 0.25C20 ampere. Charge until battery voltage (under charge) reaches 2.4 to 2.45vpc. Hold at 2.40 to 2.45vpc until current drops to under 0.01C20 ampere. Battery is fully charged under these conditions, and charger should be disconnected or switched to “float” voltage.

Temperature Coefficient: Adjust Charging Voltage to +/- 0.005vpc/C, 0.003vpc/F from 25°C / 77°F.

Performance Characteristics

